



HS-60A Model

### Introduction

Since 1980, Eaton’s Innovative Technology has provided Surge Protective Devices (SPDs) to power quality equipment users around the world. Whatever your electrical surge protection need may be, Eaton’s Innovative Technology has a Surge Protective Device to fill it!

### General Features

- Description — 120 and 250 V, Series or parallel wired, terminal strip connected, Multi-stage Hybrid **Active Tracking Network (ATN®)** enhanced sine wave tracking surge protective device
- Application — Dedicated ac power circuits, ≤60 amps, feeding variable speed drives, variable frequency drives, process controllers, PLCs, power supplies, microprocessor-based loads, CNCs and a wide variety of other mission-critical and general-purpose individual loads
- Warranty — 10-Year Free Replacement
- Unit Listings — Recognized components under UL® 1449 Second Edition, UL® 1283
- Manufacturer Qualifications — ISO® 9001:1994 Quality System Certification BSI FM 30833

### Mechanical and Electrical Features

- Enclosure — ABS Plastic UL® 94-5VA
- Connection — Stud-lugs
- Weight — ≈ 1 lb (0.45 kg)
- Operating Temperature — -40°F (-40°C) to +140°F (+60°C)
- Circuit Description — Multi-stage hybrid network utilizing circuit encapsulation and Advanced Surge Path Technology
- Protection Modes — All Mode: Dedicated L-N (normal mode), Dedicated L-G, N-G (common mode)
- Input Power Frequency — 0 – 64 Hz (ac)
- Response Time — Active < 1 nanosecond

### Maximum EMI/RFI Attenuation — Mil-Std-220

1 kHz	10 kHz	100 kHz	1 MHz	10 MHz	Maximum Attenuation Frequency
3 dB	20 dB	37 dB	31 dB	17 dB	38 dB @ 176 kHz

- Maximum Continuous Operating Current — 60 Amps rms up to 250 volts
- Circuit Interrupt — Reference installation instructions for details

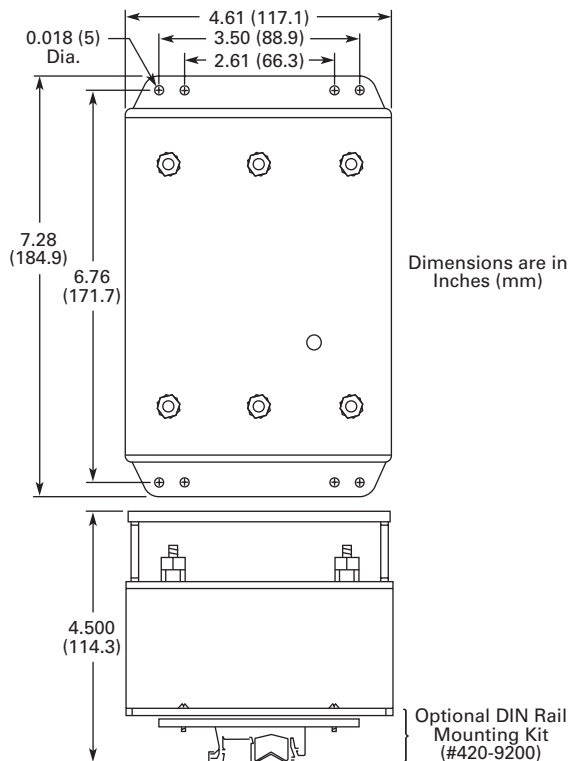

## Performance Data

Available Models	Peak Surge Current Phase/Mode	Nominal System Voltage (AC-Vrms, DC-Vpk)	ANSI/IEEE C62.41-1991 Measured Limiting Voltage *			UL SVR
			A1 Ring Wave 2 kV, 67 A 180° Phase Angle	A3 Ring Wave 6 kV, 200 A 90° Phase Angle	B3/C1 Impulse Wave 6 kV, 3 kA 90° Phase Angle	UL 1449-2 Suppressed Voltage Ratings
			L-N L-G, N-G	L-N L-G, N-G	L-N L-G, N-G	L-N L-G, N-G
cRU <sub>US</sub> HS-120-60A	80 kA/40 kA	48 – 150 Vac 48 – 200 Vdc	30 70, 40	240 350, 130	420 450, 430	400 400, 400
cRU <sub>US</sub> HS-250-60A	80 kA/40 kA	120 – 275 Vac 120 – 300 Vdc	50 80, 40	400 520, 140	770 790, 770	800 800, 800

\* Test environment: Positive polarity. Tested with AC power applied. All units tested at terminals, time base = 1 ms. All measurements referenced from zero volts per NEMA® LS-1.

Innovative Technology is a registered service mark of Eaton Corporation.  
 Active Tracking Network (ATN) is a registered trademark of Eaton Corporation.  
 UL is a federally registered trademark of Underwriters Laboratories Inc.  
 ISO is the registered trademark and sole property of the International Organization for Standardization.  
 NEMA is the registered trademark and service mark of the National Electrical Manufacturers Association.

**Eaton Corporation**  
**Innovative Technology TVSS Products**  
 1000 Cherrington Parkway  
 Moon Township, PA 15108-4312  
 USA  
 Phone: 1-800-525-2000  
 Web: www.itvss.com

**COMPONENT  
 LEVEL FUSING**

EXCLUSIVE  
 10 YEAR



©2004–2007 Eaton Corporation  
 All Rights Reserved  
 Printed in USA  
 Form No. PS01006043E / Z2990  
 May 2007

