



PTX160/PTE160 Protectors

Introduction

Since 1980, Eaton’s Innovative Technology has provided Surge Protective Devices (SPDs) to power quality equipment users around the world. Whatever your electrical surge protection need may be, Eaton’s Innovative Technology has a Surge Protective Device to fill it!

General Features

- Peak Surge Current — 160 kA per phase; 80 kA per mode
- ANSI/IEEE C62.41 Location Categories — A, B and C
- Application — High to Low Exposure Level, sensitive, mission critical load applications including: distribution panels, branch panels and critical load centers.
- Warranty — 20-Year Free Replacement
- Unit Listings — UL® 1449 Second Edition, cUL®, UL® 1283 filter
- Manufacturer Qualifications — ISO® 9001:1994 Quality System Certification BSI FM 30833

Mechanical and Electrical Features

- Enclosure — Powder Coated Steel, weatherproof; NEMA® Type 4 (IP66), meets or exceeds Type 12, 13 & 3R
- Mounting — Internally threaded fittings and multi-point mounting feet
- Connection — #10 (6 mm²) stranded wire
- Weight — 12 lbs (5.5 kg)
- Operating Temperature — -40°F (-40°C) to +185°F (85°C)

- Protection Modes — All Mode L-N, L-L (normal mode), L-G, N-G (common mode)
- Input Power Frequency — PTX: 47 – 420 Hz; PTE & all -SD optioned units: 47 – 64 Hz,
- Response Time — PTX: ≤1 nanosecond, PTE Active: <1 nanosecond
- Capacitance — PTE: Up to 10 µF per mode

Note: For applications where earth leakage current may be of concern, please utilize PTX models.

- Diagnostics — LED indicators, 1 per phase, normally on. Remote Alarm Form C (Volt Free), NO or NC contacts
 - Contact rating 60 W, or 125 Vac @ 0.5 Amp, or 30 Vdc @ 1 Amp
 - Internal terminal strips and weatherproof fitting
 - Optional S.M.A.R.T. (surge counter and phase loss indicator with audible alarm)
- Circuit Interrupt Requirement — Reference installation instructions for details

Maximum EMI/RFI Attenuation — Mil-Std-220

1 kHz	10 kHz	100 kHz	1 MHz	10 MHz	Maximum Attenuation Frequency
3 dB	21 dB	40 dB	21 dB	5 dB	40 dB @ 98 kHz

Optional Features and Equipment

- Active Tracking Network (ATN®) — PTE models
- Audible Alarm, Surge Counter and Phase Loss Monitor (S.M.A.R.T.) — (-SD suffix)
- Stainless Steel, Type 4X enclosure — (-SS suffix) (contact factory, minimum quantities apply)
- Fused — (-L suffix) (See web site for current field drawings)
- Fused Disconnect — (-D suffix) (See web site for current field drawings)

Innovative Technology is a registered service mark of Eaton Corporation. UL and cUL are federally registered trademarks of Underwriters Laboratories Inc. ISO is the registered trademark and sole property of the International Organization for Standardization. NEMA is the registered trademark and service mark of the National Electrical Manufacturers Association. Active Tracking Network (ATN) is a registered trademark of Eaton Corporation.

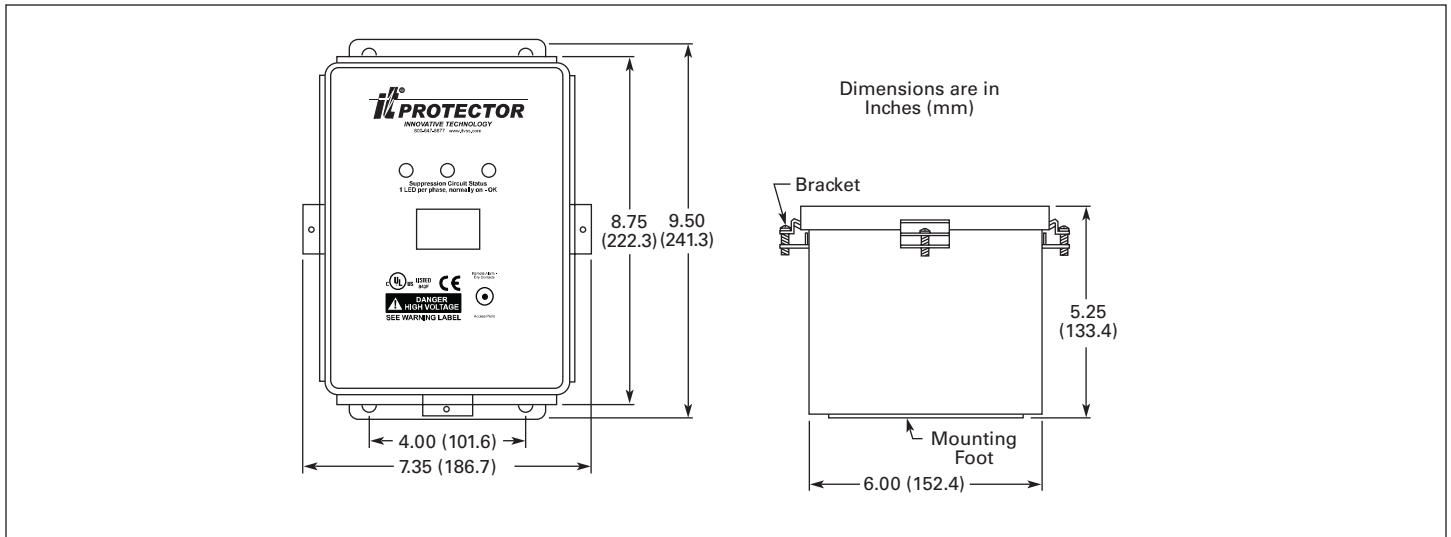

Performance Data

ANSI/IEEE C62.41-1991 Measured Limiting Voltage *

UL SVR

PTX160 PTE160	System Config	Nominal System Voltage	MCOV	PTE Models A1 Ring Wave 2 kV, 67 A 180° Phase Angle				PTE Models A1 Ring Wave 2 kV, 67 A 90° Phase Angle		ALL Models B3/C1 Impulse 6 kV, 3 kA 90° Phase Angle		ALL Models C3 Impulse 20 kV, 10 kA 90° Phase Angle		UL 1449-2 Suppressed Voltage Ratings	
				L-N L-G HiL-N	L-L N-G HiL-G	L-N L-G HiL-N	L-L N-G HiL-G	L-N L-G HiL-N	L-L N-G HiL-G	L-N L-G HiL-N	L-L N-G HiL-G	L-N L-G HiL-N	L-L N-G HiL-G		
1P101	Single-Phase 2w+grnd	100, 110, 120, 127	150	70 110	— 90	250 390	— 240	550 580	— 530	1030 1210	— 1130	400 400	— 400		
1P201	Single-Phase 2w+grnd	200, 208, 220, 230, 240, 277	320	80 150	— 100	480 520	— 90	990 1060	— 960	1580 1840	— 1650	800 800	— 800		
1S101	Split-Phase 3w+grnd	100/200, 110/220, 120/240, 127/254	150/300	70 110	80 90	250 390	280 240	550 580	910 530	1030 1210	1340 1130	400 400	800 400		
3Y101	3-Phase Y/Star 4w+grnd	100/175, 110/190, 120/208, 127/220	150/300	70 110	80 90	250 390	280 240	550 580	910 530	1030 1210	1340 1130	400 400	800 400		
3Y201	3-Phase Y/Star 4w+grnd	220/380, 230/400, 240/415, 277/480	320/640	80 150	110 100	480 520	830 90	990 1060	1700 960	1580 1840	2310 1650	800 800	1500 800		
3Y300	3-Phase Y/Star 4w+grnd	305/525, 347/600	420/840	70 730	90 850	580 620	1020 100	1220 1280	2140 1190	1770 1880	2680 1760	1000 1000	2000 1000		
3D101	3-Phase Δ (Hi-Leg) 4w+grnd	120/240	150/300	80 120 80	380 90 120	250 290 380	380 90 430	580 970 990	930 830 980	1390 1630 1840	1550 1500 1640	400 400 800	1500 400 800		
NN201	3-Phase Δ 3w+grnd	200, 208, 220, 230, 240	320	— 610	70 —	— 670	410 —	— 970	950 —	— 1440	1490 —	— 800	800 —		
NN400	3-Phase Δ 3w+grnd	380, 400, 415, 440, 480	580	— 1180	70 —	— 1280	770 —	— 1750	1730 —	— 2390	2390 —	— 1500	1500 —		
NN501	3-Phase Δ 3w+grnd	525, 600	750	— 1350	90 —	— 1650	970 —	— 2130	2160 —	— 2990	2890 —	— 2000	2000 —		

* Test environment: All tests performed with 6" lead length, positive polarity. Voltages are peak ±10%. Measurements are taken from zero reference per NEMA LS-1.

Eaton Corporation
Innovative Technology TVSS Products
 1000 Cherrington Parkway
 Moon Township, PA 15108-4312
 USA
 Phone: 1-800-525-2000
 Web: www.itvss.com



©2004–2007 Eaton Corporation
 All Rights Reserved
 Printed in USA
 Form No. PS01006009E / Z2990
 May 2007